



APPROVAL SHEET
FOR
MAGNETIC BUZZER

深圳市銳創達電子有限公司

TAT ELECTRONICS CO. LTD.

CUSTOMER:

PART NUMBER: BPC3025W150-1235

CUSTOMER PART NO.:

CUSTOMER	APPROVED	CHECKED
	钟云莎	蒋寅
SIGNECTURE (Customer)	SIGNECTURE (Company)	

Add: Rm 1610,Pengji Wisdom Center,Bagua 1st Rd,Futian Dist,Shenzhen, Guangdong, China

深圳市福田区八卦一路鹏基商务时空 1610

Tel:+86-755-8950 9282, 8237 0515;

Fax:+86-755-89509880

Email: tatspeaker@tatelec.com;

[Http:// www.tatelec.com](http://www.tatelec.com).



Specification for Piezoelectric Ceramic Buzzer With built-in oscillating circuit(Lead Wire Type)		Update/09B11	Page 2 of 3
		Des.	Chk.
Model No.:	BPC30MW150-1235	Li YanFei	Jiang Yin
		2/21/2022	2/21/2022

1. SPECIFICATION

Piezoelectric Ceramic Element
Built-in oscillating circuit

1	Dimension	$\Phi 29.5 \times H24.0$
2	Net Weight	Approx 7.0g
3	Rated Voltage	12 VDC
4	Operating Voltage	5~18 VDC
5	Rated Current	Max.40mA at 12VDC
6	Sound Output	Min. 90dB at 12VDC,30cm
7	Resonant Frequency	$3500 \pm 500\text{Hz}$
8	Tone	Continuous
9	Operating Temperature	$-20^{\circ}\text{C} \sim +70^{\circ}\text{C}$
10	Store Temperature	$-30^{\circ}\text{C} \sim +80^{\circ}\text{C}$
11	Lead Wire	$L1=150.0 \pm 5.0, \Phi=1.2 \pm 0.2\text{mm}$

Dimensions

Unit: mm

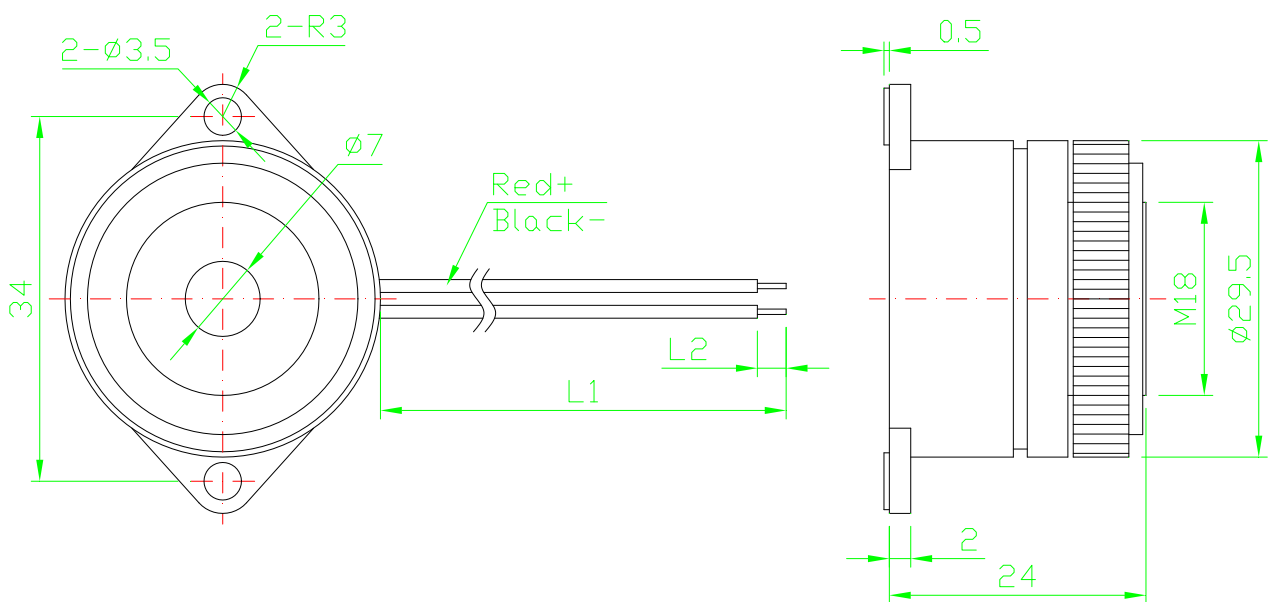

*Unit: mm; Tolerance: $\pm 0.5\text{mm}$ Except Specified

*Housing Material: Black PBT



Specification for Piezoelectric Ceramic Buzzer With built-in oscillating circuit(Lead Wire Type)		Update/09B11	Page 3 of 3
		Des.	Chk.
Model No.:	BPC30MW150-1235	Li YanFei	Jiang Yin
		2/21/2022	2/21/2022

2. Reliability Test

After any following tests the part shall meet specifications without any degradation in appearance and performance except SPL. SPL shall not deviate more than -10 dB from the initial value

2.1 Ordinary Temperature Life Test

The part shall be subjected to 96 hours at $25 \pm 10^\circ\text{C}$. Input rated voltage Resonant frequency, 1/2 duty Square wave.

2.2 High Temperature Test

The part shall be capable of with standing a storage temperature of $+85^\circ\text{C}$ for 96 hours.

2.3 Low Temperature Test

The part shall be capable of with standing a storage temperature of -40°C for 96 hours.

2.4 Humidity Test

Temperature: $+40^\circ\text{C} \pm 3^\circ\text{C}$ Relative Humidity: 90%~95% Duration: 48 hours and expose to room temperature for 6 hours

2.5 Temperature Shock Test

Temperature: 70°C /1hour \rightarrow 25°C /3hours \rightarrow -30°C /1hour \rightarrow 25°C /3hours (1cycle)
Total cycle: 10 cycles

2.6 Drop Test

Standard Packaging From 1.2m(Drop on hard wood or board of 5cm thick, three sides, six plain.)

2.7 Vibration Test

Vibration: 1000cycles /min. Amplitude: 1.5mm, Duration: 1 hour in each 3 axes

Note:

As this product is not protected from foreign material entering, please make sure that any foreign materials (e.g. magnetic powder, washing solvent, flux, corrosive gas) do not enter this product in your production processes. The functional degradation (e.g. SPL down) may occur if foreign material enter it.

3. Electrical And Acoustical Measuring Condition

3.1 Recommended Setting

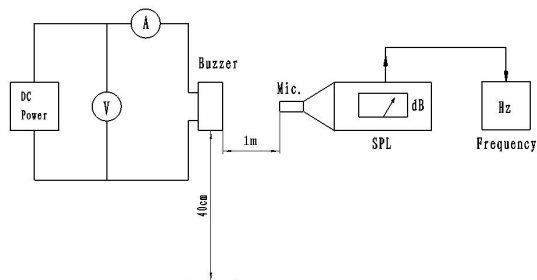

3.2 Recommended Test Circuit

